

型號	內輪內徑	外輪外徑	外輪內徑	內輪外徑	高度	基本定格荷重		極限轉速(rpm)		鋼球	
	d	D	d1	D1	H	C	CO	脂潤滑	油潤滑	個數	直徑
F3-8M	3	8	3.2	7.8	3.5	600	480	11000	15000	6	1.588
F4-9M	4	9	4.2	8.8	4	800	520	8000	12000	6	1.588
F4-10M	4	10	4.2	9.8	4	658	580	6000	10000	6	1.588
F5-10M	5	10	5.2	9.8	4	950	830	5100	8100	7	1.588
F5-11M	5	11	5.2	10.8	4.5	988	880	5000	8000	7	1.588
F5-12M	5	12	5.2	11.8	4	988	880	5000	8000	7	1.588
F6-12M	6	12	6.2	11.8	4.5	1600	1255	5000	7000	8	2
F6-14M	6	14	6.25	13.8	5	1800	1588	4000	7000	8	2.381
F7-13M	7	13	7.2	16.8	4.5	1422	1255	4000	7000	9	2
F7-15M	7	15	7.2	14.8	5	2200	2000	3600	7100	8	2.5
F7-17M	7	17	7.2	16.8	6	2600	2256	3500	7000	8	2.381
F8-16M	8	16	8.2	15.8	5	3000	2500	4000	8000	9	3
F8-19M	8	19	8.2	18.8	7	3452	3000	3000	5000	8	3.175
F9-17M	9	17	9.2	16.8	5	627	578	2500	4500	10	2.381
F9-20M	9	20	9.2	19.8	7	3356	2999	2500	4500	8	3.175
F10-18M	10	18	10.2	17.8	5.5	2721	2230	2500	4500	10	2.381

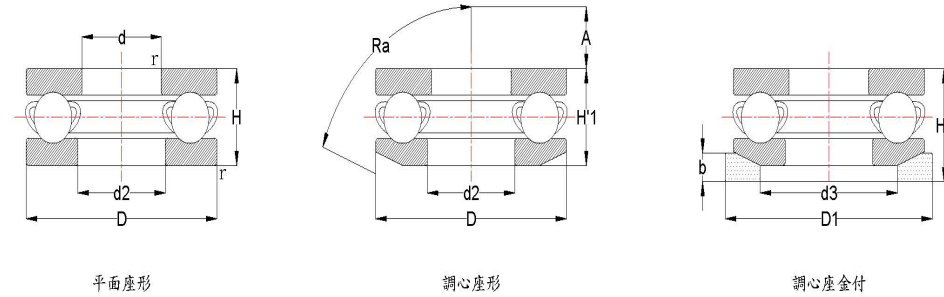

基本型號			主要寸法(mm)						基本定格荷重(kgf)		極限速率(rpm)	
平面座形	調心座形	調心座金付	d	D	H	H1	H1	r	C	CO	脂潤滑	油潤滑
51100			10	24	9			0.5	795	1180	6700	10000
51200	53200	53200U		26	11	11.6	13	1	1010	1440	6000	9000
51101			12	26	9			0.5	820	1300	6700	10000
51201	53201	53201U		28	11	11.4	13	1	1050	1610	5600	8500
51102			15	28	9			0.5	835	1420	6300	9500
51202	53202	53202U		32	12	13.3	15	1	1320	2100	5000	7500
51103			17	30	9			0.5	905	1650	6300	9500
51203	53203	53203U		35	12	13.2	15	1	1360	2320	5000	7500
51104			20	35	10			0.5	1190	2250	5300	8000
51204	53204	53204U		40	14	14.7	17	1	1770	3200	4000	6000
51105			25	42	11			1	1560	3150	4500	6700
51205	53205	53205U		47	15	16.7	19	1	2210	4250	3800	5600
51305	53305	53305U		52	18	19.8	22	1.5	2840	5200	3200	4800
51405	53405	53405U		60	24	26.4	29	1.5	4400	7550	2600	4000

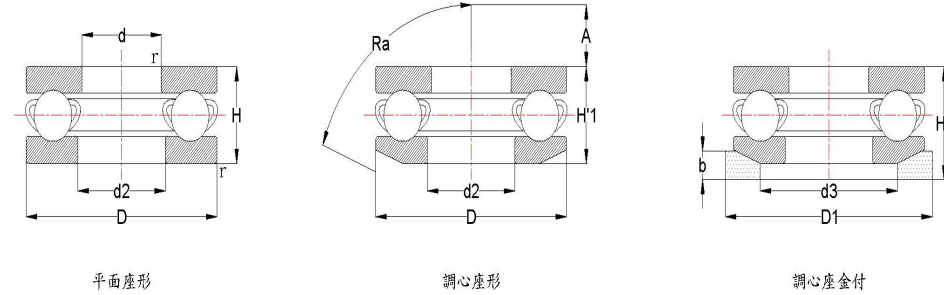

基本型號			主要寸法(mm)						基本定格荷重(kgf)		極限速率(rpm)	
平面座形	調心座形	調心座金付	d	D	H	H'1	H1	r	C	CO	脂潤滑	油潤滑
51106			30	47	11			1	1640	3550	4300	6500
51206	53206	53206U		52	16	17.8	20	1	2340	4900	3400	5300
51306	53306	53306U		60	21	22.6	25	1.5	3400	6650	2800	4200
51406	53406	53406U		70	28	30.1	33	1.5	5800	10600	2200	3400
51107			35	52	12			1	1760	4200	4000	6000
51207	53207	53207U		62	18	19.9	22	1.5	3100	6600	3000	4500
51307	53307	53307U		68	24	25.6	28	1.5	4400	8850	2500	3700
51407	53407	53407U		80	32	34	37	2	6900	13100	2000	3000
51108			40	60	13			1	2160	5300	3600	5300
51208	53208	53208U		68	19	20.3	23	1.5	3750	8300	2800	4200
51308	53308	53308U		78	26	28.5	31	1.5	5500	11400	2200	3300
51408	53408	53408U		90	36	38.2	42	2	8150	15900	1700	2600
51109			45	65	14			1	2240	5850	3400	5000
51209	53209	53209U		73	20	21.3	24	1.5	3850	8850	2600	4000
51309	53309	53309U		85	28	30.1	33	1.5	6350	13800	2000	3000
51409	53409	53409U		100	39	42.4	46	2	10100	20800	1600	2400
51110			50	70	14			1	2310	6350	3200	4800
51210	53210	53210U		78	22	23.5	26	1.5	3900	9400	2400	3600
51310	53310	53310U		95	31	34.3	37	2	7700	17000	1800	2800
51410	53410	53410U		110	43	45.6	50	2.5	11600	24400	1400	2200

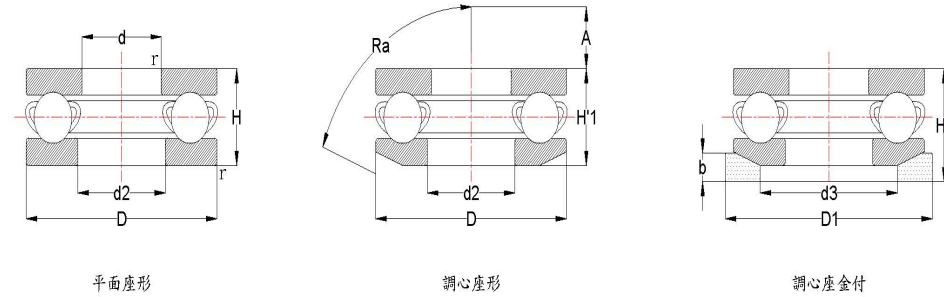

基本型號			主要寸法(mm)						基本定格荷重(kgf)		極限速率(rpm)	
平面座形	調心座形	調心座金付	d	D	H	H'1	H1	r	C	CO	脂潤滑	油潤滑
51111			55	78	16			1	2790	7850	2800	4300
51211	53211	53211U		90	25	27.3	30	1.5	5550	13400	2100	3200
51311	53311	53311U		105	35	39.3	42	2	9100	20600	1600	2400
51411	53411	53411U		120	48	50.5	55	2.5	14300	29500	1300	1900
51112			60	85	17			1.5	3300	9500	2600	4000
51212	53212	53212U		95	26	28	31	1.5	5700	14300	2000	3000
51312	53312	53312U		110	35	38.3	42	2	9400	22200	1600	2400
51412	53412	53412U		130	51	54	58	2.5	16000	33500	1200	1800
51113			65	90	18			1.5	3350	9900	2500	3800
51213	53213	53212U		100	27	28.7	32	1.5	6000	15900	1900	2800
51313	53313	53313U		115	36	39.4	43	2	9700	23800	1600	2300
51413	53413	53413U		140	56	60.2	65	3	18400	41500	1100	1600
51114			70	95	18			1.5	3450	10700	2400	3600
51214	53214	53214U		105	27	28.8	32	1.5	5900	15900	1900	2800
51314	53314	53314U		125	40	44.2	48	2	10800	26400	1400	2000
51414	53414	53414U		150	60	63.6	69	3	19900	46500	1000	1500

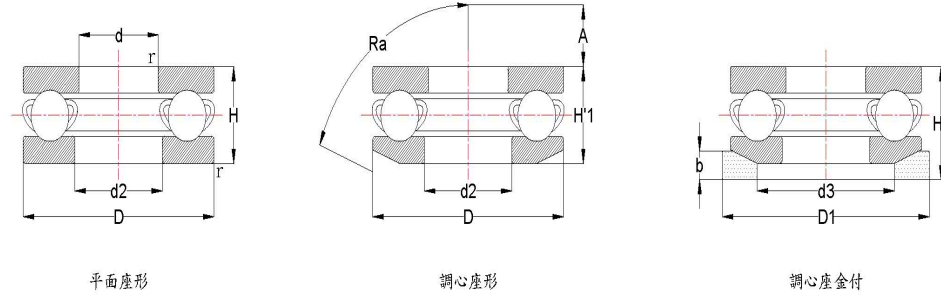

基本型號			主要寸法(mm)						基本定格荷重(kgf)		極限速率(rpm)	
平面座形	調心座形	調心座金付	d	D	H	H'1	H1	r	C	CO	脂潤滑	油潤滑
51115			75	100	19			1.5	3500	11100	2200	3400
51215	53215	53215U		110	27	28.3	32	1.5	6200	17600	1800	2700
51355	53315	53315U		135	44	48.1	52	2.5	12500	31000	1300	1900
51415	53415	53415U		160	65	69	75	3	20100	47500	950	1400
51116			80	105	19			1.5	3550	11900	2200	3300
51216	53216	53216U		115	28	29.5	32	1.5	6300	18500	1700	2600
51316	53316	53316U		140	44	47.6	52	2.5	13000	33000	1200	1800
51416	53416	53416U		170	68	72.2	78	3.5	21500	52500	900	1400
51117			85	110	19			1.5	3650	12700	2200	3200
51217	53217	53217U		125	31	33.1	37	1.5	7650	22300	1600	2400
51317	53317	53317U		150	49	53.1	58	2.5	16400	41500	1100	1700
51417	53417	53417U		180	72	77	83	3.5	24400	63500	850	1300
51118			90	120	22			1.5	4800	16100	2000	3000
51218	53218	53218U		135	35	38.5	42	2	9050	26200	1400	2200
51318	53318	53318U		155	50	54.6	59	2.5	16900	44000	1100	1600
51418	53418	53418U		190	77	81.2	88	3.5	26000	70000	800	1200
51120			100	135	25			1.5	6800	22600	1700	2600
51220	53220	53220U		150	38	40.9	45	2	10700	31500	1300	1900
51320	53320	53320U		170	55	59.2	64	2.5	18800	50500	1000	1500
51420	53420	53420U		210	85	90	98	4	29300	83000	710	1100

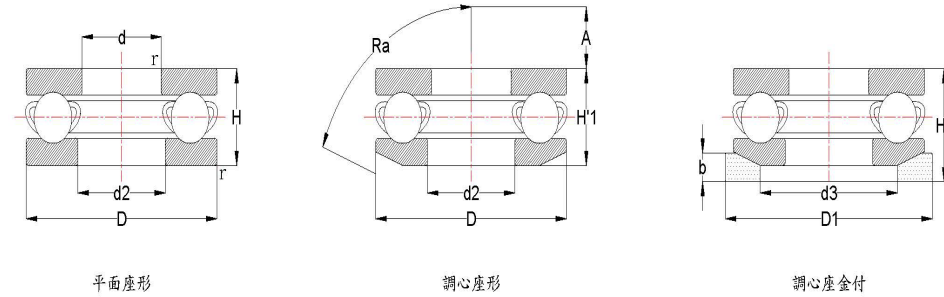

基本型號			主要寸法(mm)						基本定格荷重(kgf)		極限速率(rpm)	
平面座形	調心座形	調心座金付	d	D	H	H'1	H1	r	C	CO	脂潤滑	油潤滑
51122			110	145	25			1.5	6850	23500	1600	2400
51222	53222	53222U		160	38	40.2	45	2	10800	35500	1200	1900
51322	53322	53322U		190	63	67.2	72	3	22300	63500	900	1300
51422	53422	53422U		230	95	99.7	109	4	32500	97500	630	950
51124			120	155	25			1.5	7100	26000	1600	2400
51224	53224	53224U		170	39	40.8	46	2	11200	36500	1200	1800
51324	53324	53324U		210	70	74.1	80	3.5	25900	78500	800	1200
51424	53424	53424U		250	102	107.3	118	5	38000	118000	600	850
51126			130	170	30			1.5	8100	28700	1400	2000
51226	53226	53226U		190	45	47.9	53	2.5	14600	46500	1100	1600
51326	53326	53326U		225	75	80.3	86	3.5	27600	86500	750	1100
51426	53426	53426U		270	110	115.2	128	5	41500	134000	530	800
51128			140	180	31			1.5	8300	31000	1300	2000
51228	53228	53228U		200	46	48.6	55	2.5	14800	48500	1000	1500
51328	53328	53328U		240	80	84.9	92	3.5	29300	95000	670	1000



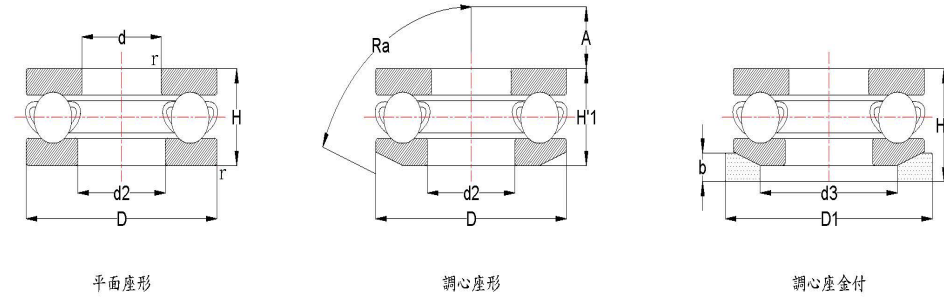

基本型號			主要寸法(mm)						基本定格荷重(kgf)		極限速率(rpm)	
平面座形	調心座形	調心座金付	d	D	H	H'1	H1	r	C	CO	脂潤滑	油潤滑
51130			150	190	31			1.5	8550	33000	1300	1900
51230	53230	53230U		215	50	53.3	60	2.5	18900	62000	950	1400
51330	53330	53330U		250	80	83.7	92	3.5	30500	101000	670	1000
51430	53430	53430U		300	120	125.9	140	5	49000	170000	480	710
51132			160	200	31			1.5	8800	35000	1200	1900
51232	53232	53232U		225	51	54.7	61	2.5	19800	68000	900	1300
51332	53332	53332U		270	87	91.7	100	4	35500	124000	600	900
51432	53432	53432U		320	130	135.3	150	6	51000	187000	450	670
51134			170	215	34			2	10500	42000	1100	1700
51234	53234	53234U		240	55	58.7	66	2.5	22300	77000	850	1200
51334	53334	53334U		280	87	91.3	100	4	37000	133000	600	900
51434	53434	53434U		340	135	141	156	6	56500	210000	430	630
51136			180	225	34			2	10800	44500	1100	1700
51236	53236	53236U		250	56	58.2	66	2.5	22600	80500	800	1200
51336	53336	53336U		300	95	99.3	109	4	38000	142000	560	800
51436	53436	53436U		360	140	148.3	164	6	59000	231000	400	600
51138			190	240	37			2	12700	52500	1000	1500
51238	53238	53238U		270	62	65.7	73	3	25500	93500	750	1100
51338	53338	53338U		320	105	111	121	5	43500	165000	500	750

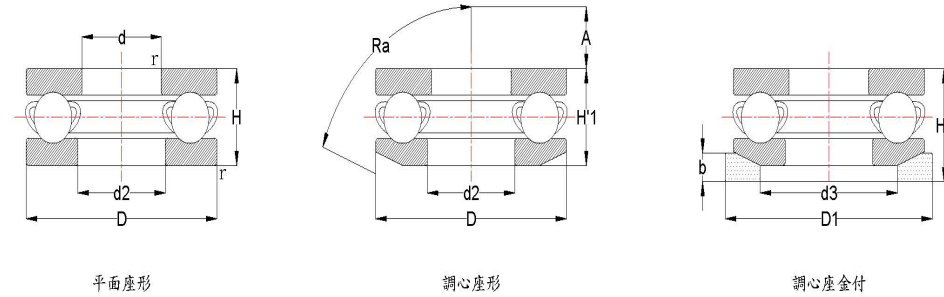

基本型號			主要寸法(mm)						基本定格荷重(kgf)		極限速率(rpm)	
平面座形	調心座形	調心座金付	d	D	H	H'1	H1	r	C	CO	脂潤滑	油潤滑
51140			200	250	37			2	12800	54000	1000	1500
51240	53240	53240U		280	62	65.3	74	3	25200	93500	710	1100
51340	53340	53340U		340	110	118.4	130	5	47500	188000	480	710
51144			220	270	37			2	13200	58500	950	1400
51244	53244	53244U		300	63	65.6	75	3	26000	102000	710	1000
51148			240	300	45			2.5	17500	77500	800	1200
51248	53248	53248U		340	78	81.6	92	3.5	33500	140000	560	850
51152			260	320	45			2.5	18100	84000	800	1200
51252	53252	53252U		360	79	82.8	93	3.5	34000	146000	560	800
51156			280	350	53			2.5	24900	111000	710	1000
51256	53256	53256U		380	80	85	94	3.5	36000	165000	530	800
51160			300	380	62			3	28400	132000	600	900
51260	53260	53260U		420	95	100.5	112	4	43000	204000	450	670
51164			320	400	63			3	29200	140000	600	900
51264	53264	53264U		440	95	100.5	112	4	46500	226000	450	670
51168			340	420	64			3	29600	149000	560	850
51268	53268	53268U		460	96	100.3	113	4	47000	236000	430	650
51172			360	440	65			3	30500	157000	560	800
51272	53272	53272U		500	110	116.7	130	5	56000	295000	380	560



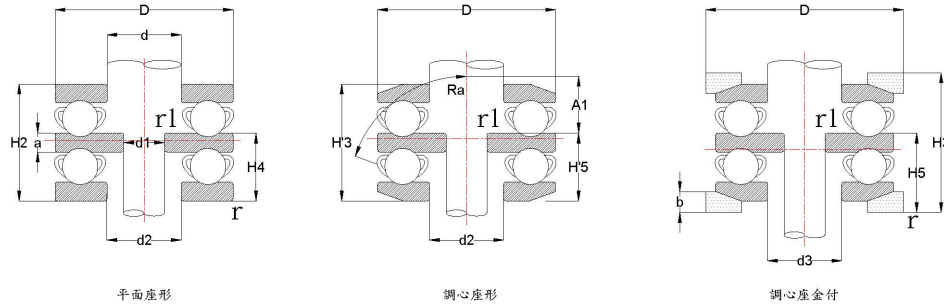

基本型號			主要寸法(mm)								基本定格荷重(kgf)		極限速率(rpm)	
平面座形	調心座形	調心座金付	d	d1	D	H2	H'3	H3	r	r1	C	CO	脂潤滑	油潤滑
52202	54202	54202U	15	10	32	22	24.6	28	1	0.5	1320	2100	5000	7500
52204	54204	54204U	20	15	40	26	27.4	32	1	0.5	1770	3200	4000	6000
52205	54205	54205U	25	20	47	28	31.4	36	1	0.5	2210	4250	3800	5600
52305	54305	54305U			52	34	37.6	42	1.5	0.5	2840	5200	3200	4800
52405	54405	54405U	30	15	60	45	49.8	55	1.5	1	4400	7550	2600	4000
52206	54206	54206U		25	52	29	32.6	37	1	0.5	2340	4900	3400	5300
52306	54306	54306U		60	38	41.2	46	1.5	0.5	3400	6650	2800	4200	
52406	54406	54406U	20	70	52	56.2	62	1.5	1	5800	10600	2200	3400	
52207	54207	54207U	35	30	62	34	37.8	42	1.5	0.5	3100	6600	3000	4500
52307	54307	54307U			68	44	47.2	52	1.5	0.5	4400	8850	2500	3700
52407	54407	54407U		25	80	59	63	69	2	1	6900	13100	2000	3000
52208	54208	54208U	40	30	68	36	38.6	44	1.5	1	3750	8300	2800	4200
52308	54308	54308U			78	49	54	59	1.5	1	5500	11400	2200	3300
52408	54408	54408U			90	65	69.4	77	2	1	8150	15900	1700	2600
52209	54209	54209U	45	35	73	37	39.6	45	1.5	1	3850	8850	2600	4000
52309	54309	54309U			85	52	56.2	62	1.5	1	6350	13800	2000	3000
52409	54409	54409U			100	72	78.8	86	2	1	10100	20800	1600	2400

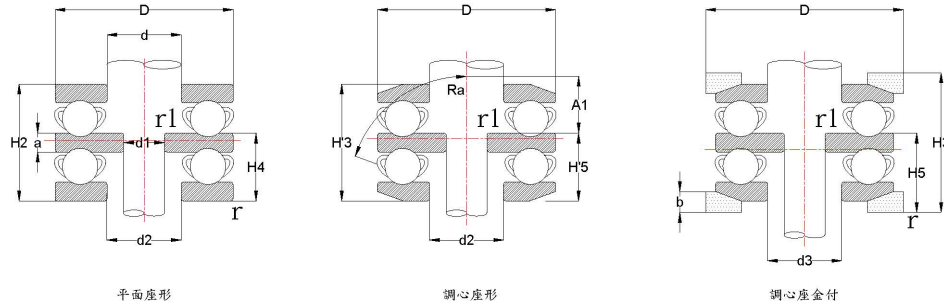

基本型號			主要寸法(mm)								基本定格荷重(kgf)		極限速率(rpm)	
平面座形	調心座形	調心座金付	d	d1	D	H2	H'3	H3	r	r1	C	CO	脂潤滑	油潤滑
52210	54210	54210U	50	40	78	39	42	47	1.5	1	3900	9400	2400	3600
52310	54310	54310U			95	58	64.6	70	2	1	7700	17000	1800	2800
52410	54410	54410U			110	78	83.2	92	2.5	1	11600	24400	1400	2200
52211	54211	54211U	55	45	90	45	49.6	55	1.5	1	5550	13400	2100	3200
52311	54311	54311U			105	64	72.6	78	2	1	9100	20600	1600	2400
52411	54411	54411U			120	87	92	101	2.5	1	14300	29500	1300	1900
52212	54212	54212U	60	50	95	46	50	56	1.5	1	5700	14300	2000	3000
52312	54312	54312U			110	64	70.6	78	2	1	9400	22200	1600	2400
52412	54412	54412U			130	93	99	107	2.5	1	16000	33500	1200	1800
52213	54213	54213U	65	55	100	47	50.4	57	1.5	1	6000	15900	1900	2800
52313	54313	54313U			115	65	71.8	79	2	1	9700	23800	1600	2300
52413	54413	54413U		50	140	101	109.4	119	3	1.5	18400	41500	1100	1600
52214	54214	54214U	70	55	105	47	50.6	57	1.5	1.5	5900	15900	1900	2800
52314	54314	54314U			125	72	80.4	88	2	1.5	10800	26400	1400	2000
52414	54414	54414U			150	107	114.2	125	3	1.5	19900	46500	1000	1500

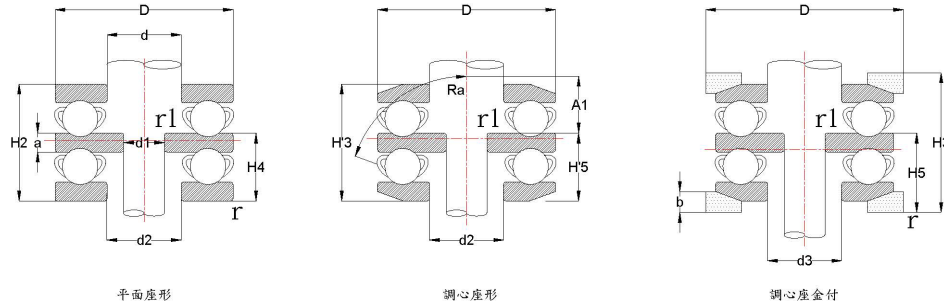

基本型號			主要寸法(mm)								基本定格荷重(kgf)		極限速率(rpm)	
平面座形	調心座形	調心座金付	d	d1	D	H2	H3	H3	r	r1	C	CO	脂潤滑	油潤滑
52215	54215	54215U	75	60	110	47	49.6	57	1.5	1.5	6200	17600	1800	2700
52315	54315	54315U			135	79	87.2	95	2.5	1.5	12500	31000	1300	1900
52415	54415	54415U			160	115	123	135	3	1.5	20100	47500	950	1400
52216	54216	54216U	80	65	115	48	51	58	1.5	1.5	6300	18500	1700	2600
52316	54316	54316U			140	79	86.2	95	2.5	1.5	13000	33000	1200	1800
52416	54416	54416U			170	120	128.4	140	3.5	1.5	21500	52500	900	1400
52217	54217	54217U	85	70	125	55	59.2	67	1.5	1.5	7650	22300	1600	2400
52317	54317	54317U			150	87	95.2	105	2.5	1.5	16400	41500	1100	1700
52417	54417	54417U		65	180	128	138	150	3.5	2	24400	63500	850	1300
52218	54218	54218U	90	75	135	62	69	76	2	1.5	9050	26200	1400	2200
52318	54318	54318U			155	88	97.2	106	2.5	1.5	16900	44000	1100	1600
52418	54418	54418U		70	190	135	143.4	157	3.5	2	26000	70000	800	1200
52220	54220	54220U	100	85	150	67	72.8	81	2	1.5	10700	31500	1300	1900
52320	54320	54320U			170	97	105.4	115	2.5	1.5	18800	50500	1000	1500
52420	54420	54420U		80	210	150	160	176	4	2	29300	83000	710	1100

# 止推滾珠軸承 內徑75~160mm

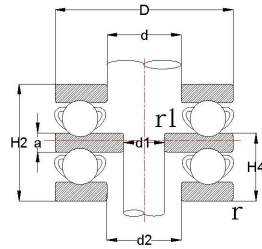

平面座形

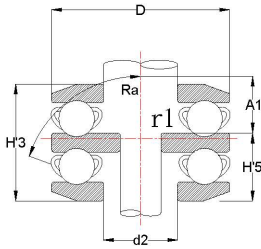

調心座形

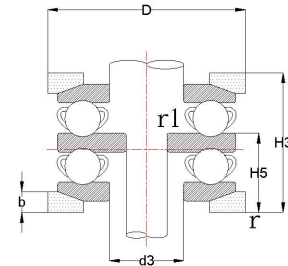

調心座金付

基本型號			主要寸法(mm)								基本定格荷重(kgf)		極限速率(rpm)	
平面座形	調心座形	調心座金付	d	d1	D	H2	H'3	H3	r	r1	C	CO	脂潤滑	油潤滑
52222	54222	54222U	110	95	160	67	71.4	81	2	1.5	10800	33500	1200	1900
52322	54322	54322U			190	110	118.4	128	3	1.5	22300	63500	900	1300
52422					230	166			4	2	32500	97500	630	950
52224	54224	54224U	120	100	170	68	71.6	82	2	2	11200	36500	1200	1800
52324	54324	54324U			210	123	131.2	143	3.5	2	25900	78500	800	1200
52424					250	177			5	2.5	38000	118000	600	850
52226	54226	54226U	130	110	190	80	85.5	96	2.5	2	14600	46500	1100	1600
52326					225	130			3.5	2	27600	86500	750	1100
52426					270	192			5	3	41500	134000	530	800
52228	54228	54228U	140	120	200	81	86.2	99	2.5	2	14800	48500	1000	1500
52328					240	140			3.5	2	29300	95000	670	1000
52428					280	196			5	3	43500	148000	530	750
52230	54230	54230U	150	130	215	89	95.6	109	2.5	2	18900	62000	950	1400
52330					250	140			3.5	2	30500	101000	670	1000
52430					300	209			5	3	49000	170000	480	710
52232	54232	54232U	160	140	225	90	97.4	110	2.5	2	19800	68000	900	1300
52332					270	153			4	2	35500	124000	600	900
52432					320	226			6	3	51000	187000	450	670